

INSPECTION CERTIFICATE

Name: Slip Elevator

Type: HYC 5.1/2"/200

Dispatch No.: 91201

The elevator is designed and manufactured in
according to API Spec 8A/8C. It has been qualified
through inspection and allowed to dispatch.

Inspector: Song Jianhua

Date: 2010-1-8



Jiangsu Rudong General Machinery CO.,Ltd.

Jiangsu Rudong General Machinery CO.,Ltd.

INSPECTION REPORT OF ELEVATOR

According to SY/5035-2004 and API Spec8A/8C, the product was tested at 1.5 times the max, load keeping five minutes. The result of test, NDE, handling property and exterior as follows:

Description (Type)	HYC 5.1/2"/200 Slip Elevator			Test load	2700 kN	
Dispatch No	91201					
Test result	OK					
MPI result	OK					
Handling property	OK					
Exterior	OK					

Inspector : Song Jianhua

Examiner: Yin Zhigao

Date: 2010-1-8



Jiangsu Rudong General Machinery CO.,Ltd.

MAGNETIC PARTICLE INSPECTION CERTIFICATE

NO.:QR049

Part Name	Slip Elevator	Type	HYC 5.1/2"/200
Dispatch No.	91201	Qty.	1 (pcs)
Material	Alloy Steel	Face estate	12.5/ <input checked="" type="checkbox"/>
Heat treatment estate	Quench and Temper	Area thickness	See below
Instrument Model	CEW-6000	Method of Magnetization	Continuum
Method of Display	Fluorescence	Sensitivity	A 15/100
Blacklight lamp	> 800uW/Cm ²	Acceptance Std.	GB9444 ASTME709

Test extent and place of assess casing:

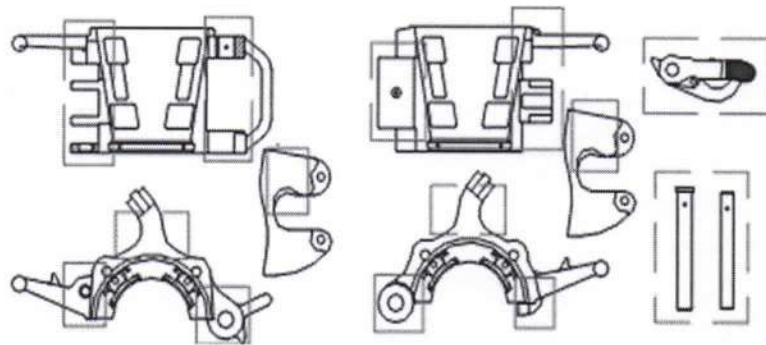

Find type of disfigurement and dimension(see above drawing)

Nonexistence

Quality grade of assess and /or conclusion:

Grade I /OK

Inspector	Xia Shupeng	Auditing	Wu Zengyi	Date(badge of department)	
-----------	-------------	----------	-----------	---------------------------	--

SHIPPING ORDER

NAME: Slip Elevator TYPE: HYC 5.1/2"/200

Net Weight: Gross Weight:

Dispatch NO.: 91201 QTY.: 1 Pcs

No.	Goods Name	QTY.	Remarks
1	Slip Elevator	1 Pcs	
2	7" Slip Segment	1 Pcs	90106
	Technical Papers		
1	Inspection Certificate	1	
2	Shipping Order	1	
3	Usage Direction	1	

Inspector : Song Jianhua Date : 2010-1-8

Jiangsu Rudong General Machinery CO.,Ltd.